

K-2 Visual and Performing Arts

WEEK 3-30-2020

Art

Music

Theatre



# ART



Name \_\_\_\_\_

Teacher \_\_\_\_\_

Directions: Draw an example of each of the Elements of Art in the correct box.

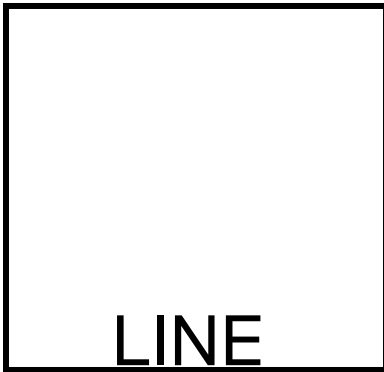

**LINE**

A mark with length and direction

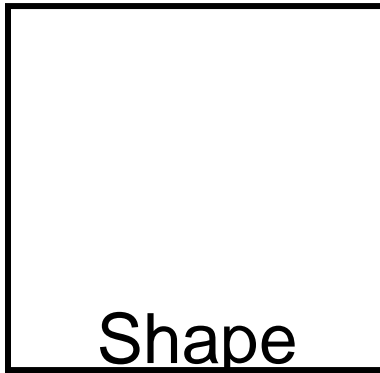

**Shape**

An enclosed area – 2d and 3d

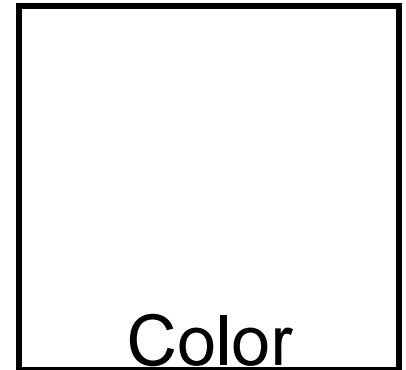

**Color**

Light strikes an object and reflects back to the eye

**The Elements of Art**  
The building blocks or ingredients in a work of art.

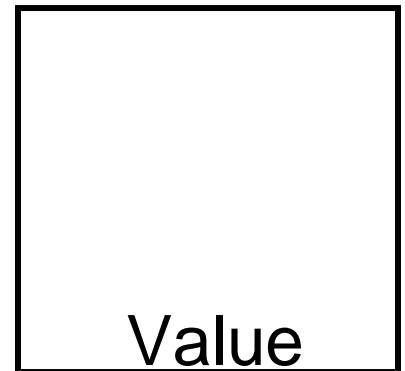

**Value**

Lightness and darkness of a color

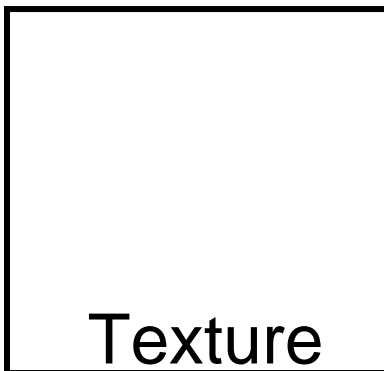

**Texture**

How something feels

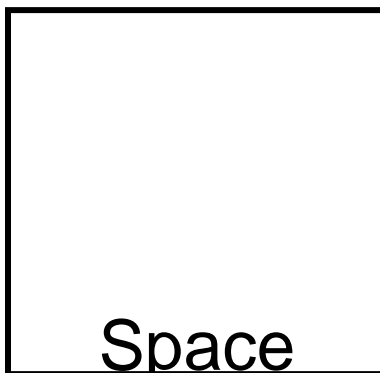

**Space**

The area above, below, around, and between objects

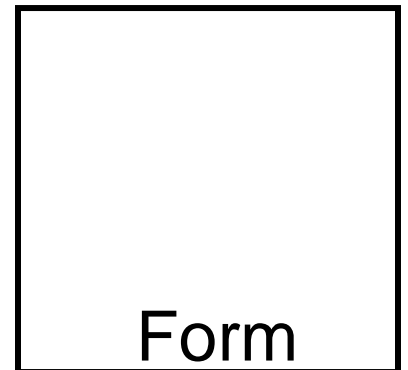





**Form**

3d object or a 2d work of art that looks 3d

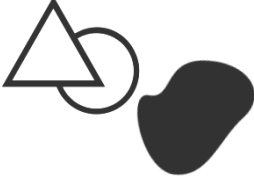
# The Elements of Art

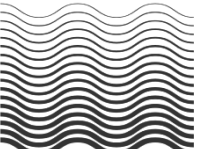
The building blocks of making art

<b>Line</b>		<p>A line is a path made by a moving point through space. It is one-dimensional and can vary in width, direction, and length.</p>
<b>Shape</b>		<p>Shapes are flat, enclosed areas that are two-dimensional (length and height). Artists use both geometric and organic shapes.</p>
<b>Color</b>		<p>Color is perceived by the way light reflects off a surface. There are three properties of color: hue (color name), intensity (strength/purity), and value (lightness and darkness).</p>
<b>Value</b>		<p>Value describes the lightness or darkness of a surface.</p>
<b>Texture</b>		<p>Texture describes the surface quality of an object. Artists use both actual texture (how things feel) and implied texture (how things look like they feel).</p>
<b>Space</b>		<p>Space is used to create the illusion of depth within an artwork. It can also refer to the positive and negative space between, around, or within objects.</p>
<b>Form</b>		<p>Forms are three-dimensional (length, width, height) and can be viewed from many angles. Forms have volume and take up space.</p>

# Draw 3D Buildings



Supplies: Graph paper, black marker, crayons.



1. Draw a horizon line.

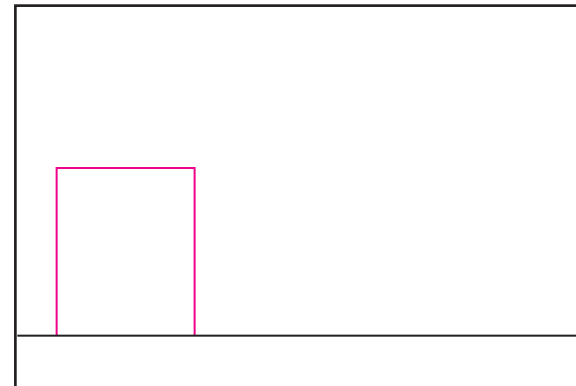

2. Start a series of rectangles.

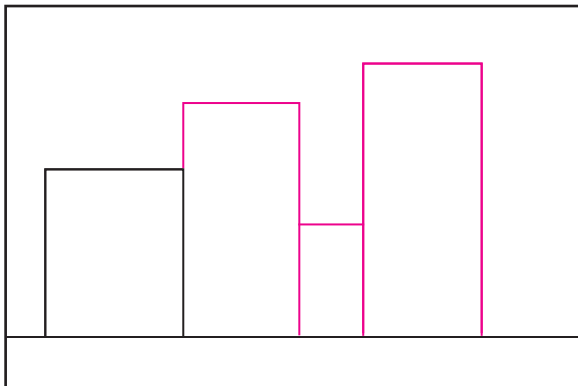

3. Make sure the rectangles all share sides.

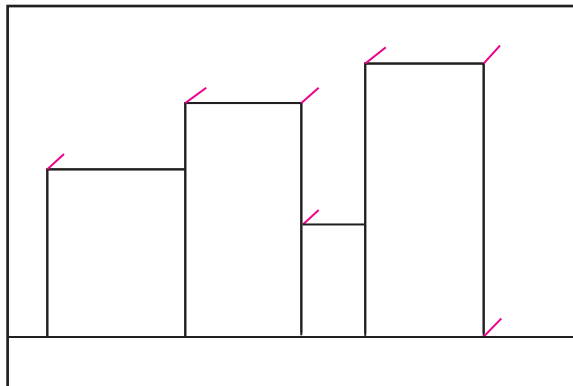

4. Add diagonal lines on the corners shown.

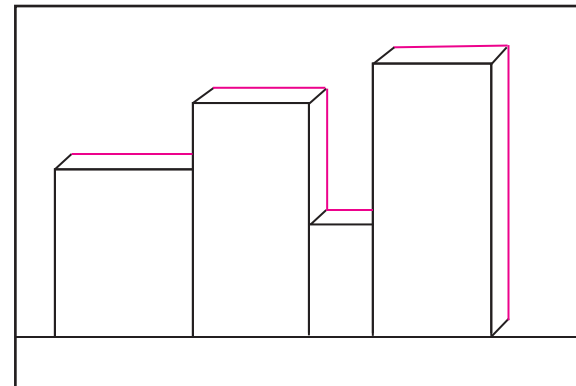

5. Finish backs with horizontal and vertical lines.



6. Add doors and lots of windows.



7. Add setting, as with trees, clouds and sun.



8. Trace, color. Press hard to make shaded sides.

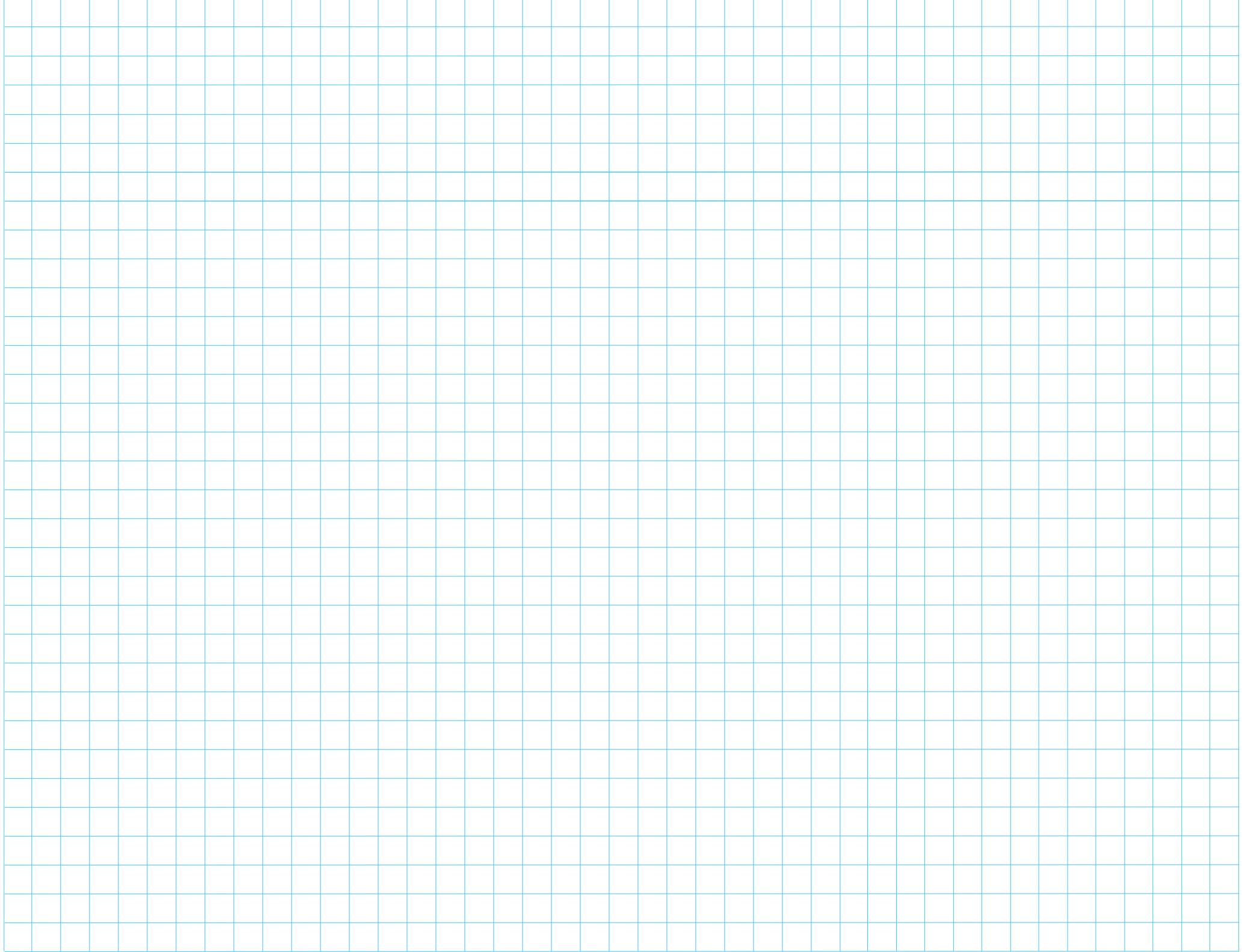

# Draw a Romero Britto Cat

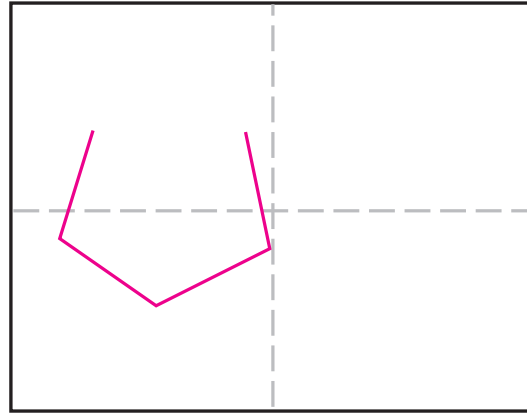

1. Make guide lines. Start the head.

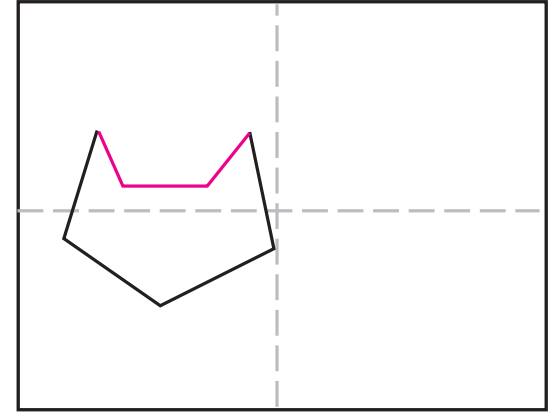

2. Draw two cat ears as shown.

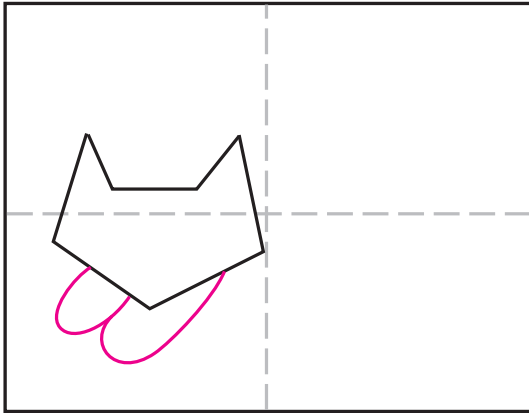

3. Draw two paws.

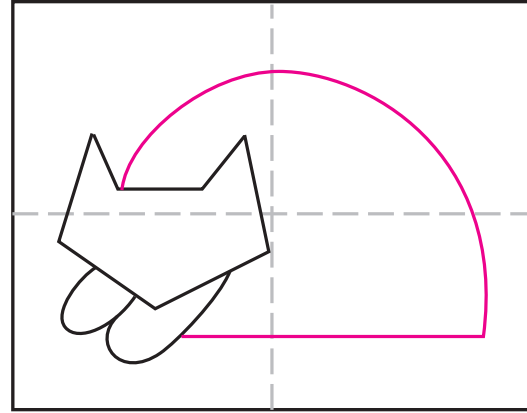

4. Draw large half circle for the body.

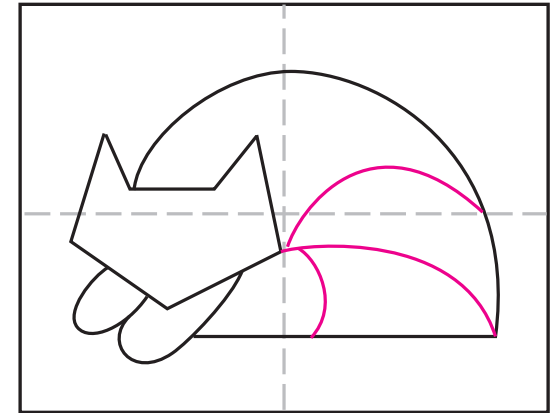

5. Draw three curved lines.

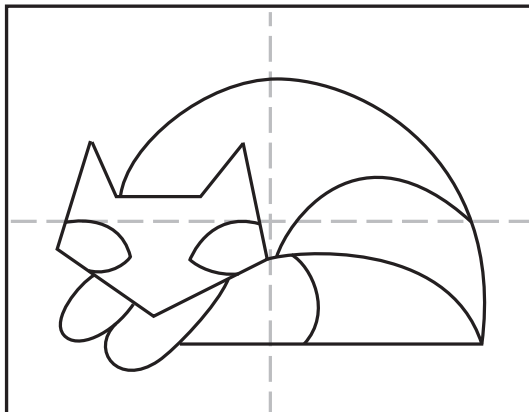

6. Draw outside of eyes.

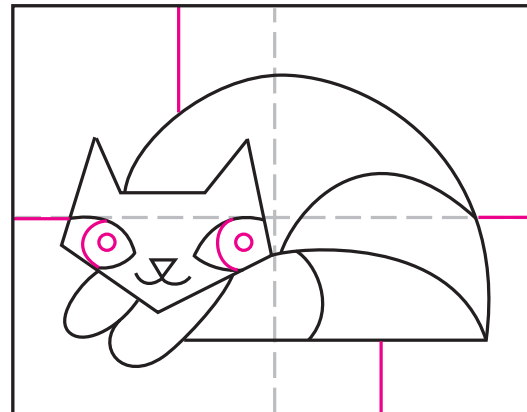

7. Draw inside eyes, and four lines.



8. Trace with a thick black marker, fill shapes. Add patterns on top afterwards.

# Draw Frida Kahlo



Supplies: Black paper, oil pastels.

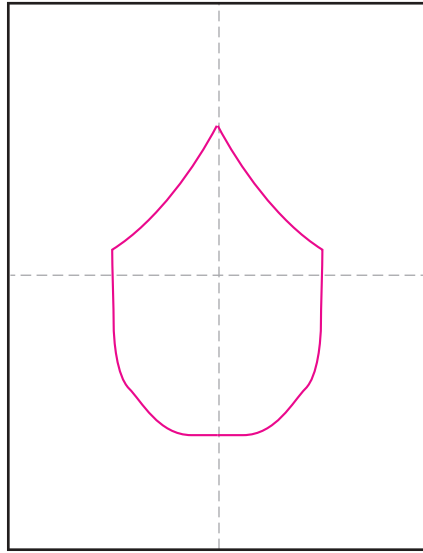

1. Make guide lines. Start the face.

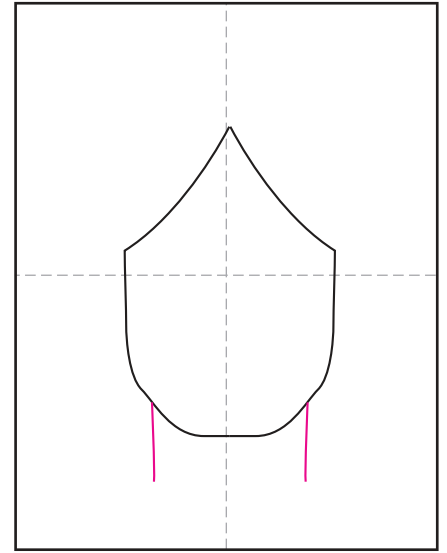

2. Add the neck.

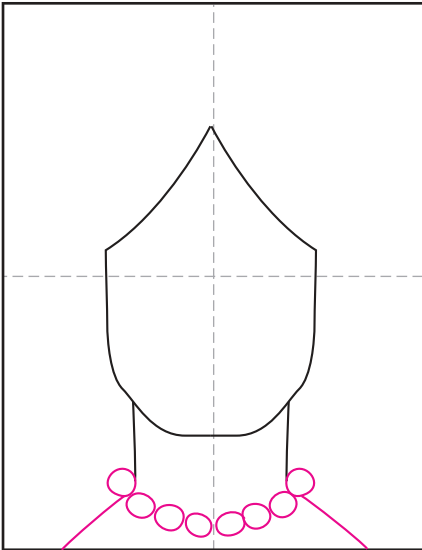

3. Draw necklace and shoulders

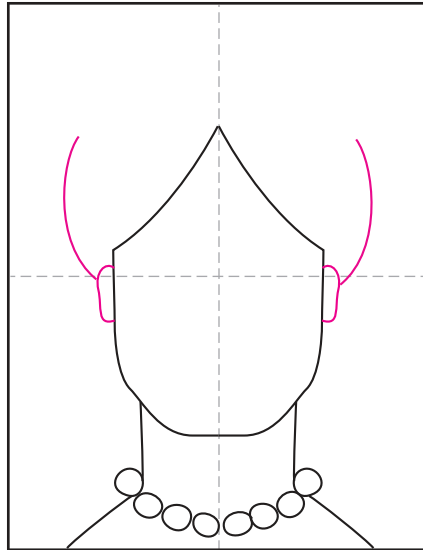

4. Draw ears and side hair.

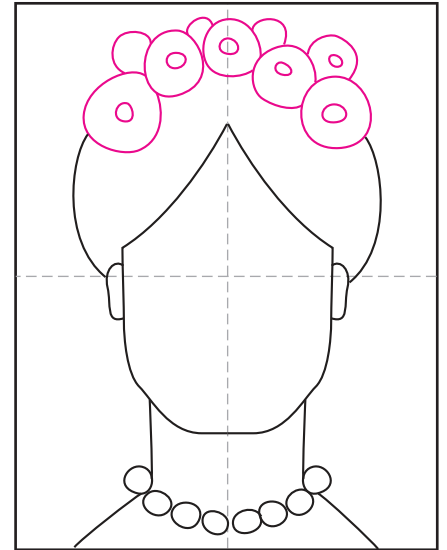

5. Add flowers on top of head.

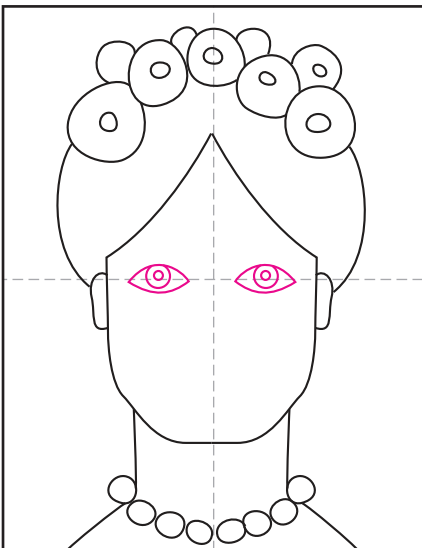

6. Draw eyes on center line.

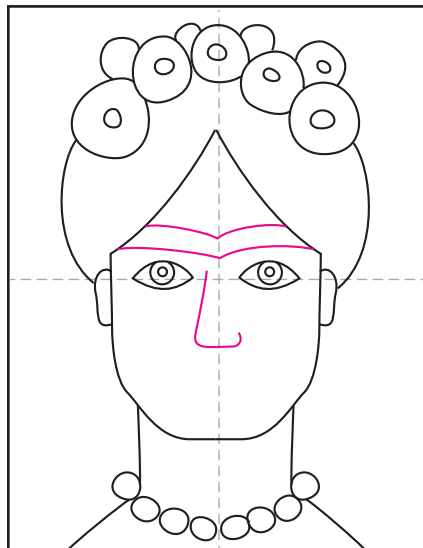

7. Add eyebrows and nose.

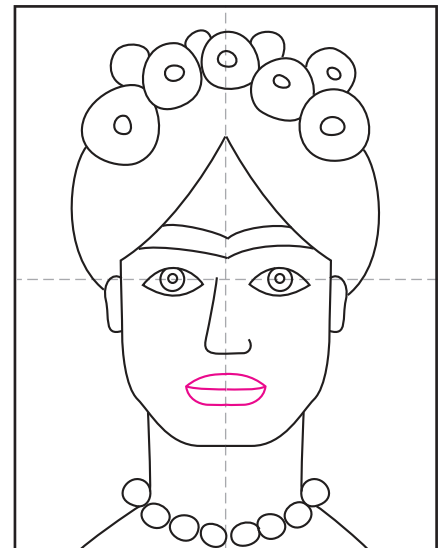

8. Finish with mouth.



# Draw a Matisse Still Life

**Art History:** Henri Matisse. **Elements of Art:** Use LINES to make SHAPES, fill with crayon TEXTURE, and paint with COLOR.

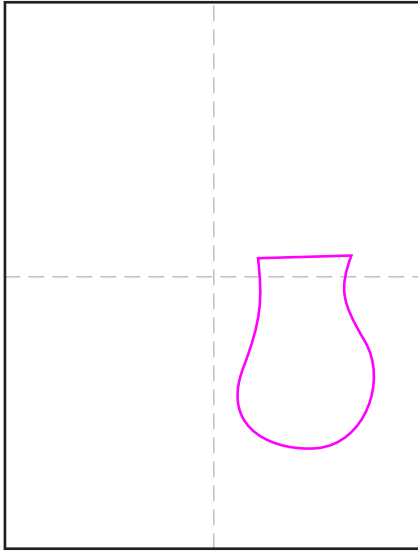

1. Draw a vase.

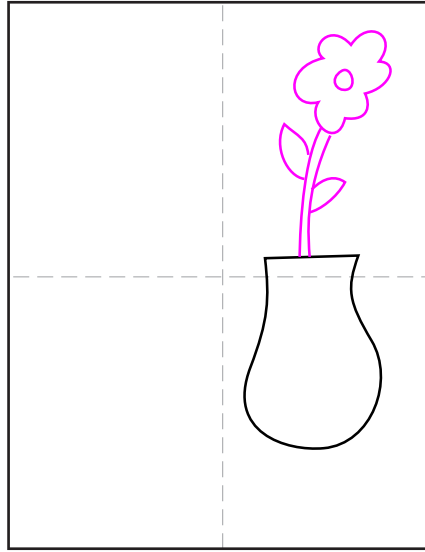

2. Draw a center flower.

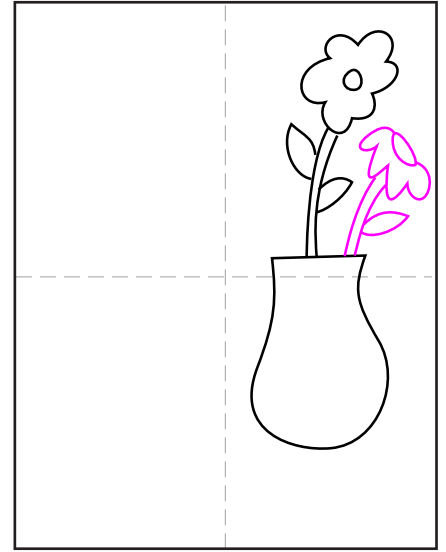

3. Draw the right flower.

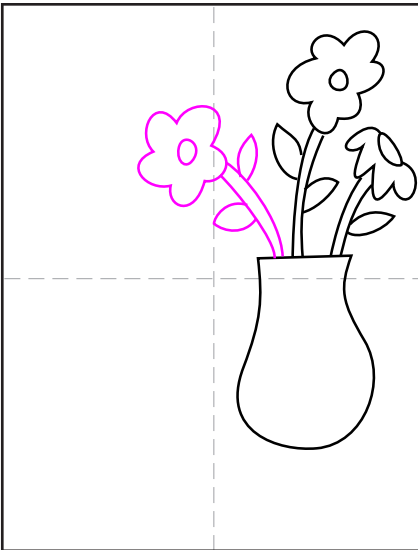

4. Draw the left flower.

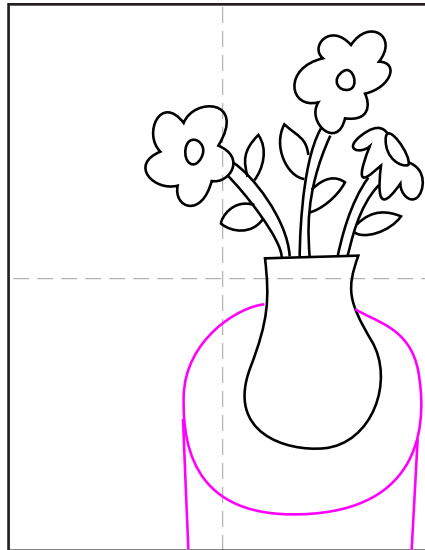

5. Draw a table.

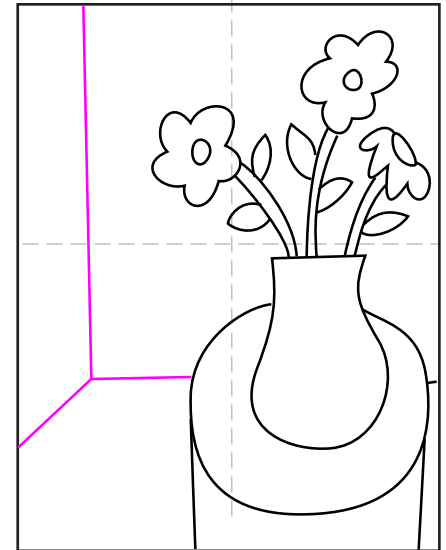

6. Draw the room lines.



7. Trace with a black marker.

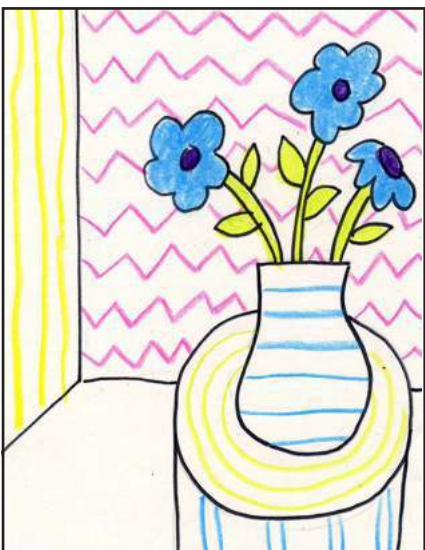

8. Add patterns with crayons.



9. Paint with watercolors.

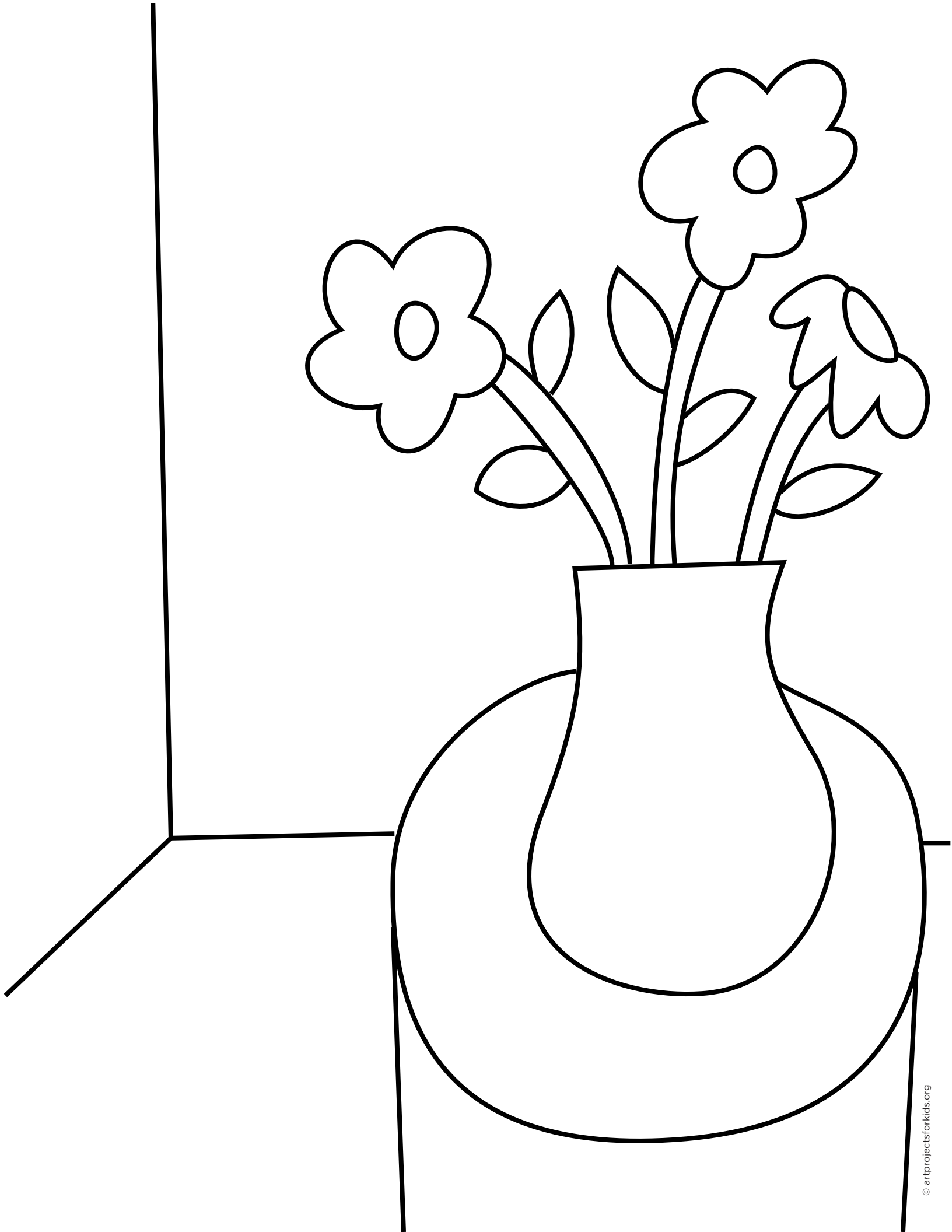

# Music



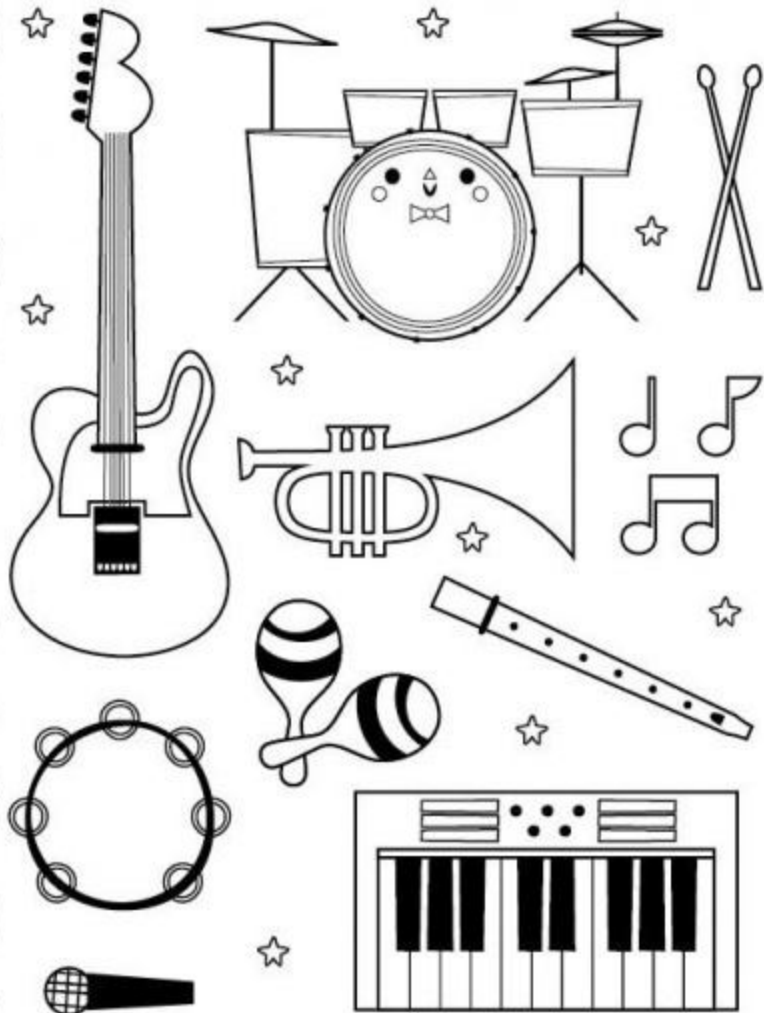

Name: \_\_\_\_\_ Date: \_\_\_\_\_

Which are the musical instruments?

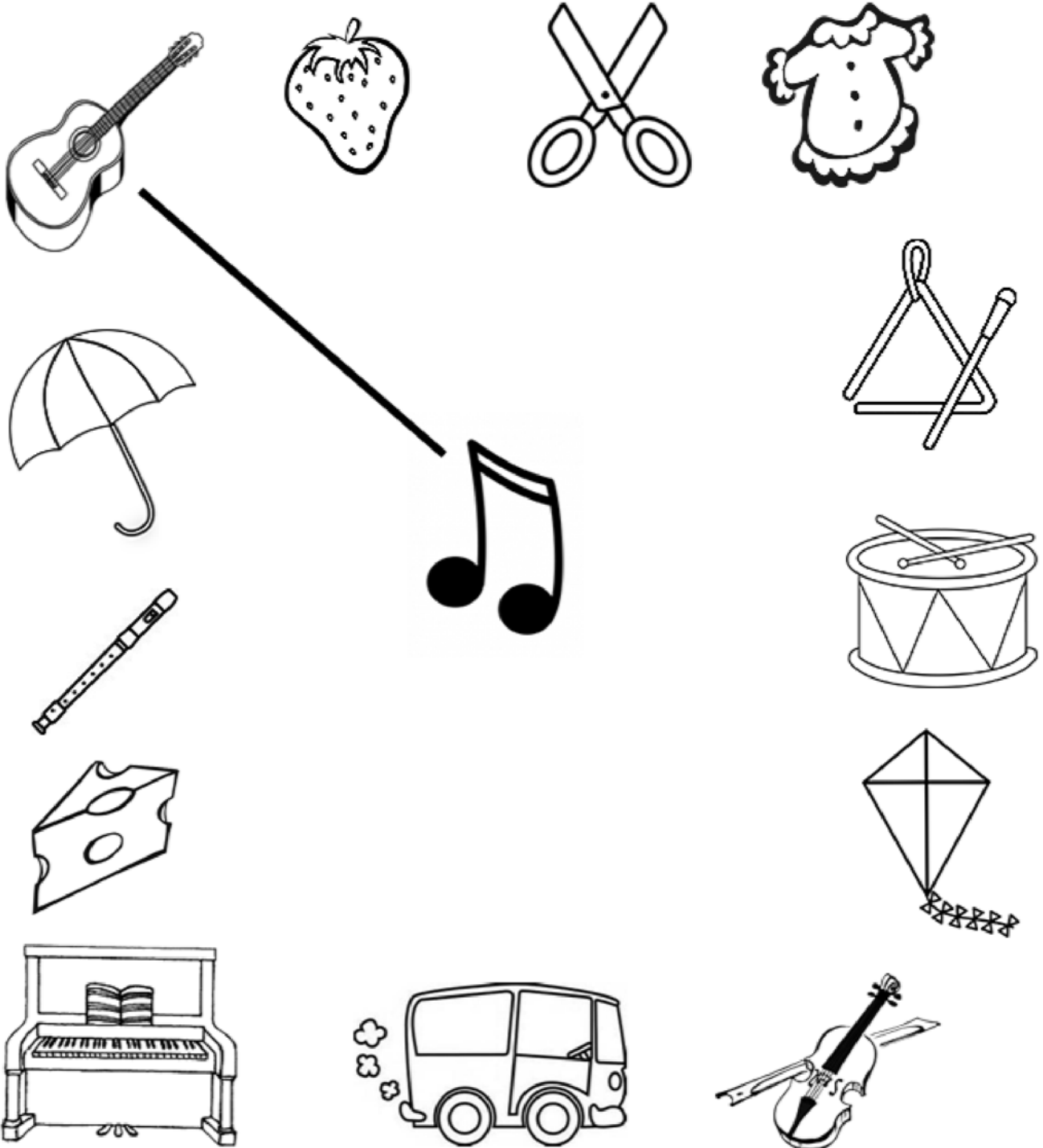

Download Free Printables at: [www.freeprintableonline.com](http://www.freeprintableonline.com)

# I SPY: INSTRUMENTS

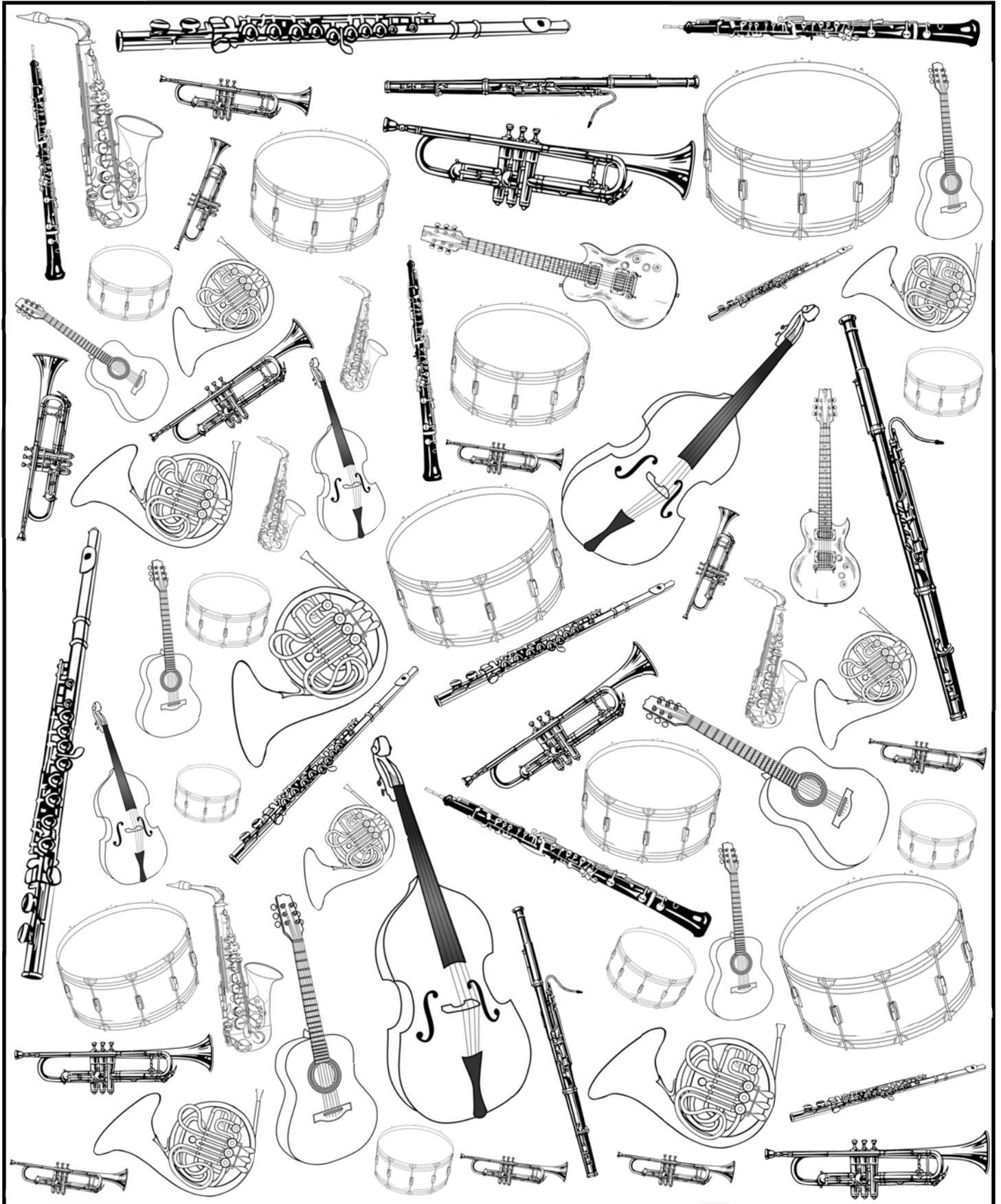

# I SPY: INSTRUMENTS

Write down the number of each item that you found.

\_\_\_\_\_ Drum



\_\_\_\_\_ French Horn

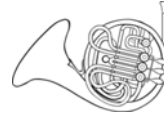

\_\_\_\_\_ Saxophone



\_\_\_\_\_ Cello



\_\_\_\_\_ Guitar



\_\_\_\_\_ Electric Guitar



\_\_\_\_\_ Trumpet



\_\_\_\_\_ Flute



\_\_\_\_\_ Oboe



\_\_\_\_\_ Bassoon



# Trace the music notes on the staff.

Name \_\_\_\_\_



Trace each pitch on a line, then fill it in.

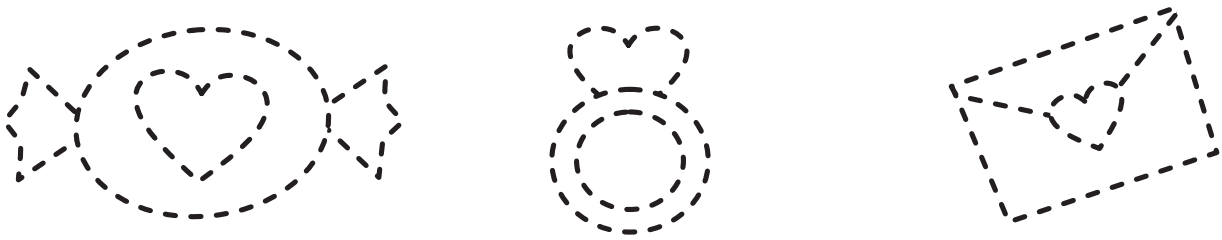
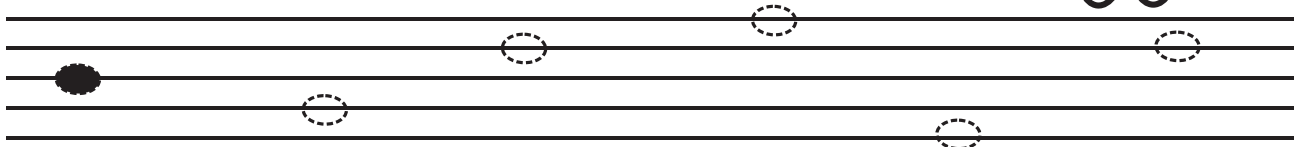

Trace each pitch in a space, then fill it in.

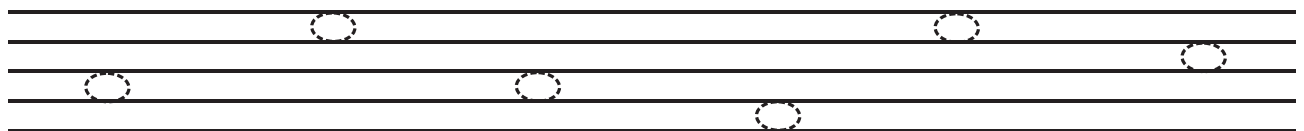



# Theatre



# ANIMALS

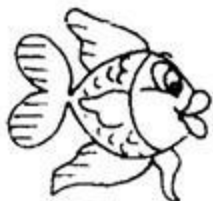
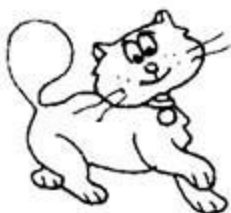
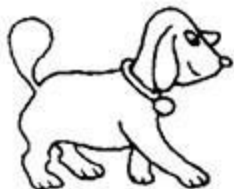

Match the images on the right with their corresponding images on the left.

# THE GREAT THEATER

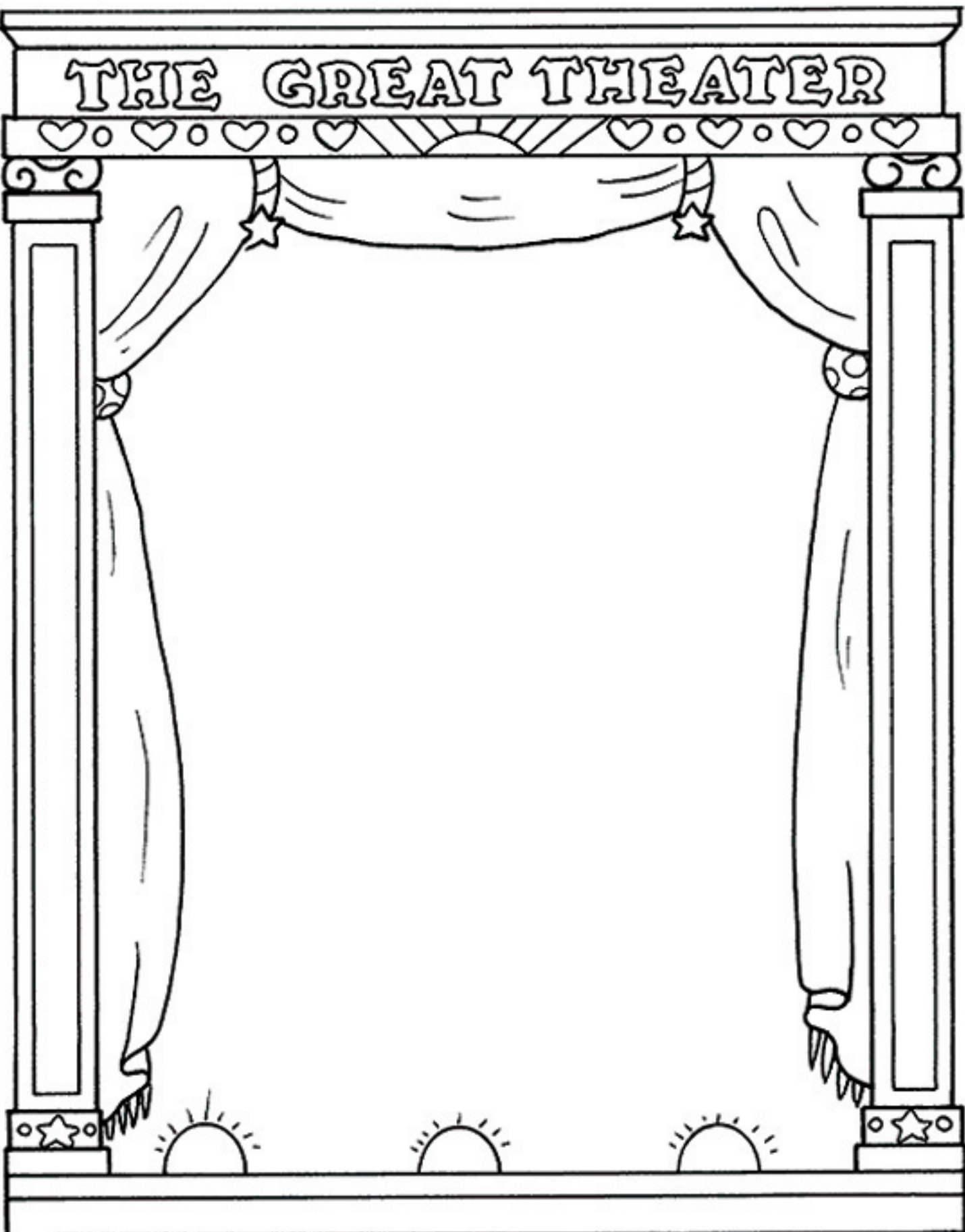

# theater



# Emotions

My name is \_\_\_\_\_

## Draw the faces



I'm happy



I'm sad



I'm sleepy



I'm afraid



I'm angry



I'm hot

# Stage Makeup



Stage makeup is an important part of any performance. Whether you use it to create a character, or just to make your own features stand out, makeup is what makes you visible to the people all the way into the back row of the audience.

Use the faces below to practice your stage makeup skills! Grab your pens, pencils, or paints and make up each face according to the caption.



***A ballerina***

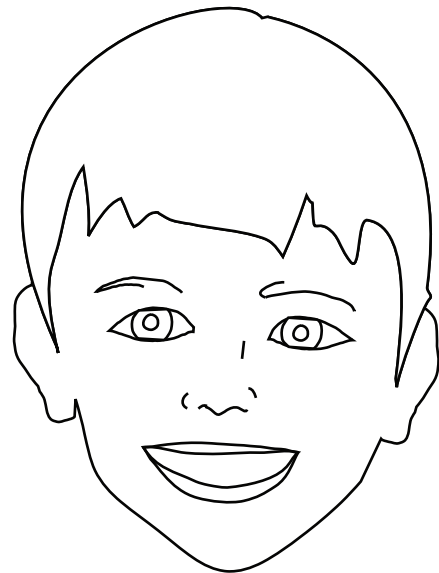

***An old man***

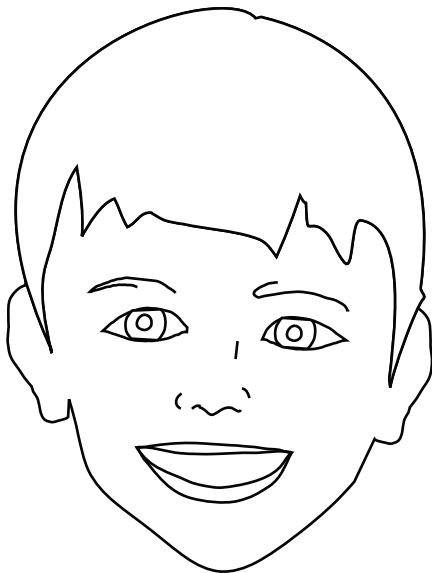

***A rock star***



***A cat***